



BROBY SKYDEVENTIL

SKANDA A/S

Den korteste vej gennem opgaveløsning til resultat

No	Part	Material
1	Body	Cast Steel GS-C25
2	Seat	Stainless steel
3	Disc	Cast steel
4	Disc holder <DN 125	Nodular cast iron
	Disc holder <DN 150	Cast Steel GS-C25
5	Disc nut	Steel
6	Stem	Stainless steel
7	Boly/Nut	Steel zincplated
8	Bonnet	Cast Steel GS-C25
9	Gland pcking	Graphite
10	Bolt	Steel zincplated
11	Gland	Nodular cast iron
12	Bushing	Gunmetal LG2
13	Washer	Gunmetal LG2
14	Handwheel	Nodular cast iron

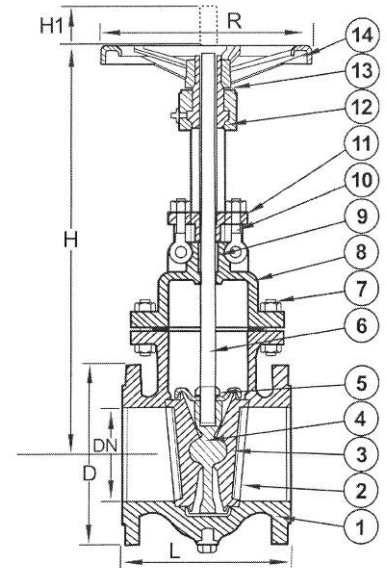

DN	D	L	H	H1	R	Max working-pressure		Weight Kg
						Mpa 150 °C	Mpa	
50	165	180	345	405	180	1,6		25,0
65	185	200	380	460	220	1,6		33,0
80	200	210	410	500	220	1,6		41,0
100	220	230	470	580	280	1,6		51,0
125	250	255	520	655	280	1,6		64,0
150	285	280	655	835	320	1,6		87,0
200	340	330	800	1035	360	1,6		162,0
250	405	380	945	1230	400	1,6		248,0
300	460	430	1100	1430	450	1,6		370,0
350	520	480	1275	1665	450	1,6		490,0



SKANDA A/S

Daniavej 35
9550 Mariager
Telefon: +45 9858 3033
Fax: +45 9858 3530
skanda@skanda.dk